

REVEL®

C540

In-Ceiling Architectural Loudspeaker Instruction Manual



EC-DECLARATION OF CONFORMITY



Brand: Revel
Family Name: Architectural Series Speakers
Model Names: C360DT, C360, C560, C760, C560DT, W360, W560, W760, C380, C580, C780, W380, W580, W780, C540, W552L, C760L, W870, W890, W970, W990

We, Harman International, declare under our sole responsibility that the product, to which this declaration relates, is in conformity with the following directives.

I certify that the product identified above conforms to the requirements of the Low Voltage Directive 2006/95/EC as amended by 93/68/EEC and the Waste from Electrical and Electronic Equipment Directive 2002/96/EC RoHS and technical standards listed below:

IEC 60065:2001 – 7th Ed. & AMD1:2005 – Safety Requirements – Audio, Video, and Similar Electronic Apparatus
EN6000-6-3:2007 – 2nd ED (EMC) –Generic standards – Emission standard for residential, commercial and light- industrial environments.
EN6000-6-1:2005 – 2nd ED (EMC) –Generic standards – Immunity standard for residential, commercial and light- industrial environments.

HpAV, part of the Harman International group of companies, declares that the products produced under the aforementioned brand names are designed and produced as professional audio speakers and therefore outside of the intended scope of the European Commission Regulation (EC) 1275/2008 of 17 December 2008 implementing Directive 2005/32/EC of the European Parliament and of the Council with regard to ecodesign requirements for standby and off mode electric power consumption of electrical and electronic household and office equipment.

Harman International expects our suppliers and business partners to be aware of their obligations under REACH and expects any substances or products within the scope of REACH to be pre-registered before December 1, 2008. Given those conditions, our current products are exempt from REACH pre-registration and later registration activities. We provide separate E.U. Reduction of Hazardous Substances documentation for our RoHS compliant products.

The WEEE directive (2002/96/EC) places an obligation on all EU-based manufacturers and importers to take-back electronic products at the end of their useful life. HpAV, through its agent, accepts its responsibility to finance the cost of treatment and recovery of redundant WEEE in accordance with the specific WEEE recycling requirements. All of our products are marked with the WEEE symbol; this indicates that this product must NOT be disposed of with other waste. Instead it is the user's responsibility to dispose of their waste electrical and electronic equipment by handing it over to an approved re-processor, or by returning it to HpAV's agent for reprocessing. For more information about where you can send your waste equipment for recycling, please contact your local distributor.

February 25, 2011
Elkhart Indiana, USA

Robert Chadderdon
Director of Engineering, HpAV

.....
(Place and Date of issue)

.....
(Name, signature and function of authorized person)

European Representative:

Andy Baker
Cranborne House
Cranborne Rd
Potters Bar
Herts EN6 3JN United Kingdom

For the technical documentation:

Sue Whitfield – sue.whitfield@harman.com

DOCUMENTATION CONVENTIONS

This document contains general safety, installation and operation instructions for the Revel® C540 in-ceiling loudspeakers. It is important to read this document before attempting to use this product. Pay particular attention to:

WARNING: Calls attention to a procedure, practice, condition or the like that, if not correctly performed or adhered to, could result in injury or death.

CAUTION: Calls attention to a procedure, practice, condition or the like that, if not correctly performed or adhered to, could result in damage to or destruction of part of or the entire product.

Note: Calls attention to information that aids in the installation or operation of the product.

ABOUT REVEL® IN-CEILING SPEAKERS

Since the first Revel® speakers in 1996, Revel products have stood at the forefront of loudspeaker design and performance. Revel in-ceiling loudspeakers draw upon the same research, resources and unique perspective that put all Revel loudspeakers in a class by themselves. Revel in-ceiling loudspeakers provide unparalleled value and are known for their standard-setting low sonic coloration and their freedom from distortion over an extraordinarily wide dynamic range.

C540 IN-CEILING LOUDSPEAKER HIGHLIGHTS

- Long-throw woofer with cast frame and rubber surround provides high output with low distortion.
- 1-inch (25mm) metal-dome tweeter with an integrated waveguide provides optimized response both on and off axis.
- High-order crossover network with premium-quality components delivers extraordinarily accurate timbre reproduction.

PRODUCT REGISTRATION

Please take a moment to register your product on our Web site at www.revelspeakers.com. You'll enable us to keep you posted on our latest advancements and help us to understand our customers and build products that meet their needs and expectations.

BOX CONTENTS

Your Revel in-ceiling loudspeaker box should contain the following items:

- 1 x Revel C540 in-ceiling loudspeaker
- 1 x round grille
- 1 x square grille
- 1 x extra scrim cloth for round grille
- 1 x extra scrim cloth for square grille
- 1 x mounting template
- 1 x instruction manual

UNPACKING THE SPEAKER

Carefully unpack the speaker. If you suspect damage from transit, report it immediately to your dealer and/or delivery service. Keep the shipping carton and packing materials for future use.

INSTALLATION CONSIDERATIONS

Your new Revel loudspeakers have been engineered to provide extremely accurate performance. However, any speaker's ultimate performance will be affected by the speaker's placement in the listening room and the acoustics of the room. Not all listening spaces can accommodate the ideal conditions of these two factors. Therefore, careful attention to the placement of your Revel in-ceiling loudspeakers will have a significant impact on the general performance of the loudspeakers.

LOUDSPEAKER PLACEMENT FOR DISTRIBUTED SOUND

- Since distributed sound is general sound throughout an area, place the loudspeakers as uniformly as possible for even sound coverage throughout the area.
- To avoid "hot spots" where the sound is too loud, plan to use more loudspeakers, with each set to play at a lower volume.
- For even coverage of all listeners in a room or area, space the speakers no more than 6.5 feet (2m) apart for 8-foot (2.5m) ceilings, or no more than 9.5 feet (2.9m) apart for 9 – 10 foot (2.7m – 3m) ceilings. Each speaker should be at least 3 feet (1m) from the nearest side wall.
- The C540's small size allows it to blend unobtrusively with typical recessed lighting fixtures.

INSTALLATION INSTRUCTIONS

CAUTION: Do not press on the tweeter mount. Doing so can damage the mount. Such damage is not covered by the speaker's warranty.

Revel architectural speakers are the most easily installed in-ceiling loudspeakers on the market. However, if you are unable to understand and follow the instructions in this manual clearly and fully, or if you are unsure of your ability to install these loudspeakers properly, please contact your dealer or a qualified installer.

WARNING: HARMAN International assumes no responsibility for improper installation of hardware or for any personal injuries or product damages resulting from improper installation or a fallen loudspeaker.



CONNECTING TO THE AMPLIFIER

CAUTION: REMOVE POWER

You must connect the speaker wires before the speaker is fully installed. To protect the audio system and yourself from damage or injury through accidental electrical shorting and surges during installation, turn all audio system power OFF before beginning the speaker installation.

Speaker Wire

Use high-quality speaker wire to obtain the best performance from your Revel in-ceiling speakers.

- For wire lengths of less than 50 ft (15m), use at least 16-gauge speaker wire.
- For wire lengths between 50 ft and 100 ft (15m – 30m), use at least 12-gauge speaker wire.
- For wire lengths of greater than 100 ft (30m), use at least 10-gauge speaker wire.

Note: All speaker wires must comply with all local building and safety codes for use in in-ceiling applications.

Making Connections

Connect each channel's positive (+) terminal on the back of the amplifier or receiver to the positive ("+" / red) terminal on the corresponding speaker; connect each channel's negative (-) terminal on the back of the amplifier or receiver to the negative ("-" / black) terminal on the corresponding speaker. Do not reverse polarities (that is, do not connect + to -, or - to +) when making connections. Doing so will cause poor imaging and diminished bass response.

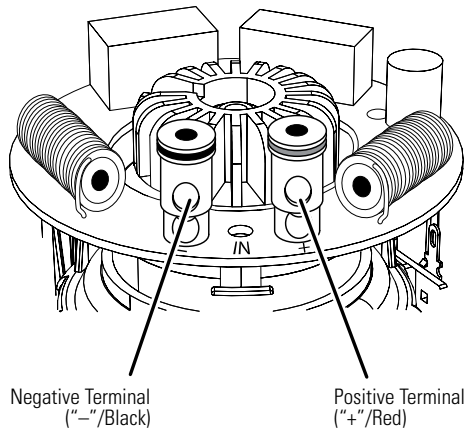

Press down on the top of the terminal to open the hole; insert the bare end of the wire into the hole; and release the terminal to secure the wire.

CAUTION: To avoid short circuits that may damage your equipment, be certain that positive and negative wire strands do not touch each other and do not touch metal parts such as the speaker frame.

MOUNTING THE SPEAKERS

For New Construction

If you wish to pre-install a rough-in frame for the speakers before the drywall is installed in new construction, you will need to purchase a PCK4C rough-in frame kit from your authorized Revel dealer. For installations that require one, a fire-rated back box (model FBB4C) is also available. Detailed instructions are supplied with the rough-in kit and back box. After the drywall is installed, follow the installation instructions in *For Existing Construction*, below.

For Existing Construction

1. Ensure that the drywall, plywood or other ceiling material is 1/2 in – 1 in (13mm – 25mm) thick and capable of withstanding the weight of the speaker being installed.

Make sure to allow at least 1-1/2" (38mm) between the edge of the supplied installation template and any rafters or other obstructions behind the wall, so the speaker's locking mechanism will have room to engage fully. Perform an obstruction survey to be sure that there are no studs, lengths of conduit, pipes, heating ducts or air returns in the ceiling cavity that will interfere with the speaker.

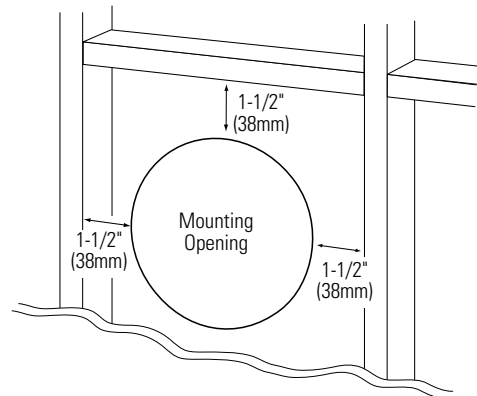

2. Determine the correct speaker location and use the template included with the speaker to mark the ceiling material.

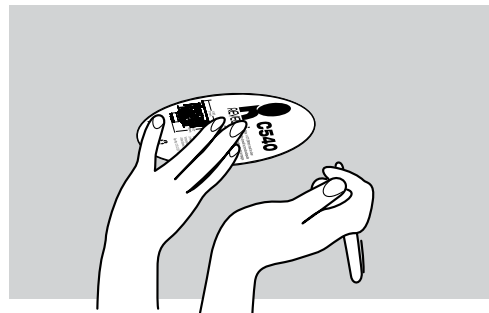

- Cut the ceiling drywall along the mark you made in Step 2 to create the mounting opening.

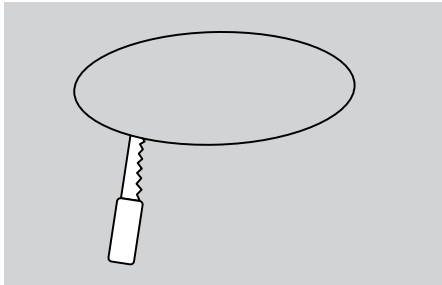

- Connect the speaker to the amplifier as explained in *Connecting to the Amplifier*, on page 4.

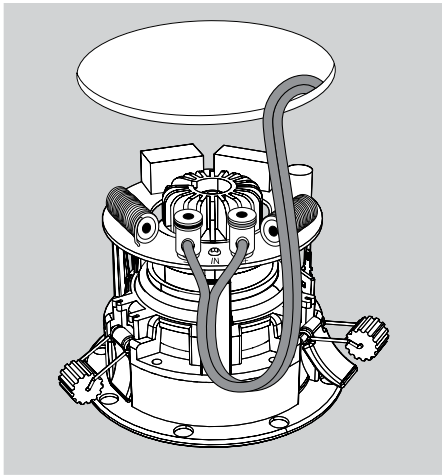

- Make sure all three Roller Lock tool-less clamps are in their locked and “ready-to-mount” position with their roller arms snapped into the holders on the speaker frame, and their trigger arms down.

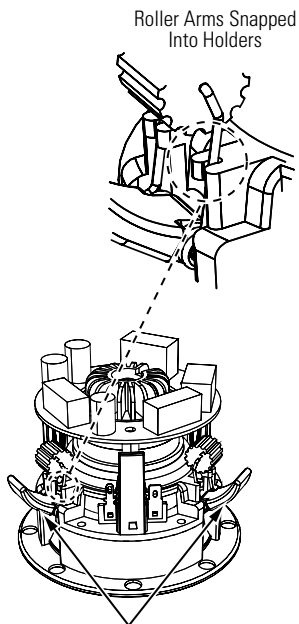

All three Roller Locks in “Ready-to-Mount” Position with Trigger Arms Down

- Carefully insert the speaker into the mounting opening, pressing evenly around the baffle. Ensure that the Roller Lock tool-less mounts are in their locked, ready-to-mount, position and that none have accidentally been pushed outside the mounting opening. As you insert the speaker, the Roller Locks will rotate into the locking position and will firmly clamp the speaker into the mounting opening.

IMPORTANT: Be sure to insert the speaker straight into the opening. Do not tilt the speaker while inserting it.

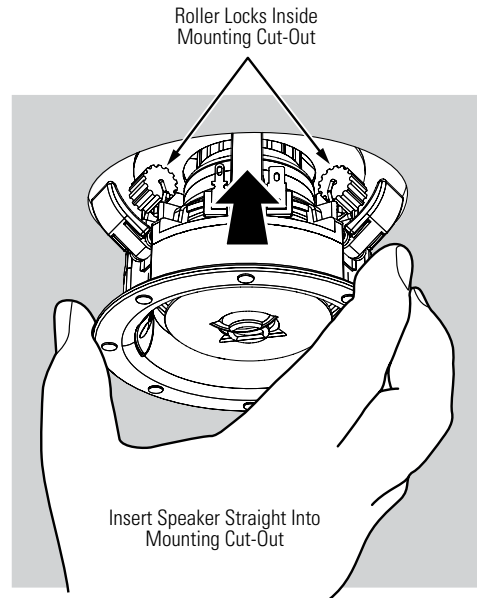

- Attach the supplied round or square grille. Powerful magnets in the speaker frame will securely hold the grille in place.

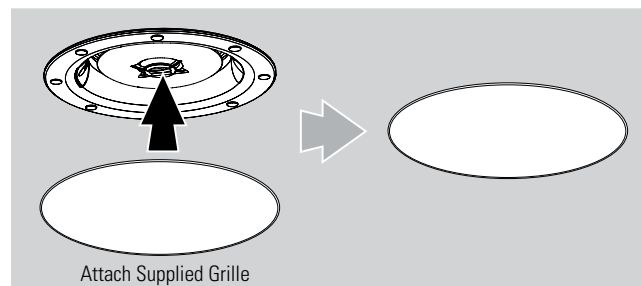

Painting the Grille

Revel architectural loudspeaker grilles can be painted to match any décor. If you wish to change the grille’s color, its satin finish will function as a primer coat. For the best results follow this procedure:

- Gently remove the scrim cloth from the back side of the grille before painting.
- Use a high-quality spray paint and apply a thin coat of color. Ensure that the grille perforations remain free of paint. Filling them with paint will diminish the speaker’s sound quality. If any perforations are plugged, use compressed air to blow the paint out of the perforations.

Note: If you find any grille perforations that are plugged with paint after the paint has dried, carefully use a straight pin or sewing needle to remove the paint.

- We have included round and rectangular replacement scrim cloths. After the paint has dried, apply a light coat of spray adhesive to the inside of the perforated grille and attach a new scrim cloth. **IMPORTANT:** Never spray adhesive on the cloth.

USING YOUR SPEAKERS

ADJUSTMENTS

Adjustable Angle Tweeter

The C540 has an adjustable angle tweeter that allows you to direct the sound toward listeners when the speaker is mounted in a less-than-ideal location. To change the angle, press on the tweeter mount, shown in gray in the illustration below. Be careful not to touch the tweeter diaphragm or suspension.

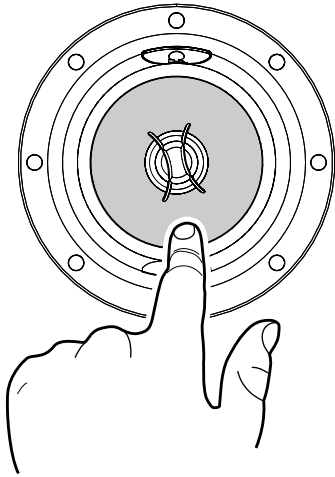

EXCESSIVE OUTPUT LEVELS

Your Revel loudspeakers feature custom-designed transducers and high-quality network components featuring high-order filters with steep cutoffs that reduce the potential of damage to individual speaker drivers and help the loudspeakers maintain their performance even under extreme operating conditions. However, all loudspeakers have limits when it comes to continuous playback. To extend these limits, avoid playback at volume levels that result in distorted or strained sound.

OBTAINING SERVICE

To obtain service, contact an authorized Revel dealer. Refer to *Limited Warranty*, below for more information.

DIMENSIONS

Mounting Opening Diameter	3-1/2" (89mm)
Mounting Depth	3-3/8" (85mm)
Overall Dimensions (w/grille)	4-3/8" (111mm) Dia. X 3-1/2" (89mm) Deep

Dimensions are subject to change without notice.

For complete performance specifications, please go to the Revel Web site: www.revelspeakers.com.

LIMITED WARRANTY

A valid serial number is required for warranty coverage. This Revel warranty protects the original retail purchaser for a period of five (5) years (parts and labor) from any failure as a result of original manufacturing defects so long as:

- The Revel products were purchased within the 50 United States, its territories or Canada.
- The dealer from whom the Revel products were purchased was authorized to sell such products at the time of the original purchase.
- The original, dated Bill of Sale is presented whenever service is required during the warranty period.

The balance of this warranty is transferable only if the used product is purchased from an authorized Revel dealer. This warranty is only valid for service within the United States, its territories and Canada; please contact an authorized Revel dealer for warranty and service information.

Any Revel product not performing satisfactorily may be returned to the factory for evaluation. Return authorization must first be obtained by either calling or writing Customer Service prior to shipping the product. The customer is responsible for shipping charges to the factory. Customer Service will pay return shipping charges within the United States only in the event that the product is found to be defective as mentioned above. There are other stipulations that may apply to shipping charges.

There is no other express warranty on this product. Neither this warranty nor any other warranty, express or implied, including implied warranties of merchantability and fitness, shall extend beyond the warranty period. No responsibility is assumed for any incidental or consequential damages, so that the above exclusion or limitation may not apply.

This warranty provides specific legal rights. Other states may provide additional rights. This warranty is applicable in the United States, its territories and Canada. Outside of the United States, its territories and Canada, please contact an authorized Revel dealer for warranty and service information.

The information this document contains is subject to change without notice. In the event that there are differences between this warranty and the provisions of any advertisements, documentation, product brochures or packaging cartons, the terms of this warranty will prevail.

www.revelspeakers.com

© 2011 HARMAN International Industries, Incorporated
All rights reserved.

Revel and the Revel logo are trademarks of HARMAN International Industries, Incorporated, registered in the United States and/or other countries.

Features, specifications and appearance are subject to change without notice.



For questions, assistance or additional information concerning any of our products, call us at: (516) 594-0300 or (888) 691-4171.
For technical support, submit your detailed inquiry to:
csupport@harman.com.

Part No. XXX-XXXX Rev.: 0